

# Skidding Systems

Feel the power





# User-friendly, modular Skidder horizontal movement of heavy

## Mastering power

Holmatro products are all about the principle that only controlled power can be deployed effectively. We have expressed this vision in the slogan 'Mastering Power' which applies perfectly to both business units that together form the Holmatro Group.

Industrial Equipment is about applying and mastering high pressure power in heavy industrial applications. And with Rescue Equipment it is a matter of life and death for fire brigades and rescue organizations to work in a controlled, precise and well-thought-out way with the proper equipment.

**CIS** LTD.  
**HYDRAULIC SOLUTIONS**

-  Powered by Holmatro
-  Holmatro Industrial Equipment
-  Holmatro Industry
-  Holmatro Industry
-  @ByHolmatro

# Lifting Systems for the heaviest loads



## Skidding Systems

# Horizontal movement of industrial objects and installations with exceptional sizes and weights

Besides the standard vertically oriented applications such as lifting and lowering, Holmatro also focusses on the horizontal movement of heavy loads. Holmatro's Skidding Systems are suitable for moving industrial objects and installations with exceptional sizes and weights to locations where using a crane is not an option.

### Modular systems; easy to adapt to different load sizes and projects

The moving and positioning of industrial objects and installations is a complex task where accuracy, stability and safety are essential. Since objects and installations differ in weight and size, every skidding project is different. To respond to this, Holmatro has developed two extremely user-friendly, modular Skidding Systems that are easy to adjust to each load size and project.

### Equal pushing and pulling capacity for controlled positioning

The principle of the Holmatro Skidding Systems is simple; each system consists of a set of tracks, beams and push-pull units with a double-acting cylinder. The load rests on the beams, which move horizontally in the tracks. To optimally guide the beams, the tracks are fitted with extremely low-friction sliding pads. The beams are connected to the push-pull units, which are fitted with a cylinder with equal pushing and pulling capacity. This allows the system to perform both

actions safely and in a controlled manner. The double-acting cylinders in the push-pull units are connected to a hydraulic pump by hoses. This powerful Twin pump has two equal oil flows that can be controlled independently or simultaneously.

### Which Skidding System suits your application best?

Holmatro offers two modular Skidding Systems. An extremely lightweight system for loads up to 200 tons, and a system for loads up to 400 tons (assuming two skidding units are used). The 200 ton Skidding System has an exceptionally low construction height and consists of lightweight components, which makes it easy to use without the help of lifting tools, such as a forklift. Installing will save you a lot of time! The lightweight system is suitable for moving objects when there is limited insertion space. The 400-ton Skidding System is extremely strong, and suitable for moving very heavy objects.

Do you need more power? The skidding capacity and control can be customized to client specifications.





**CIS** LTD.  
HYDRAULIC SOLUTIONS

# Lightweight Skidding System (200 tons)

exceptionally low and extremely lightweight (no forklift needed!)

**Holmatro's lightweight Skidding System is made of extremely lightweight components, so it can be easily carried, handled and positioned by one or two persons without the need for a forklift or the use of extra equipment. Changing the push or pull direction can be done in a split of a second!**

The maximum capacity of the system is 200 tons, assuming two skidding units are used as described in the starter kit at the next page. The total construction height is just 56 mm (2.20 inches). Despite its low height and weight, a relatively large unsupported span is possible when the surface is uneven.\*

The tracks (1), with a standard length of 1.8 meters, are easy to connect to each other by a click system. Stainless steel beams (2) are placed in the tracks. By using a push-pull bracket (3) the beams can be safely connected to the push-pull unit. With a handle on the push-pull unit (4) the push or pull direction of Holmatro's lightweight Skidding System can be switched in a split of a second. The return line of the push-pull cylinders is internal, which significantly reduces the chances of this being damaged. Because the supply and return couplers are positioned next to each other on the rear of the cylinder due to the use of the internal return line, the hoses (5) needed for ingoing and outgoing oil are of equal length.





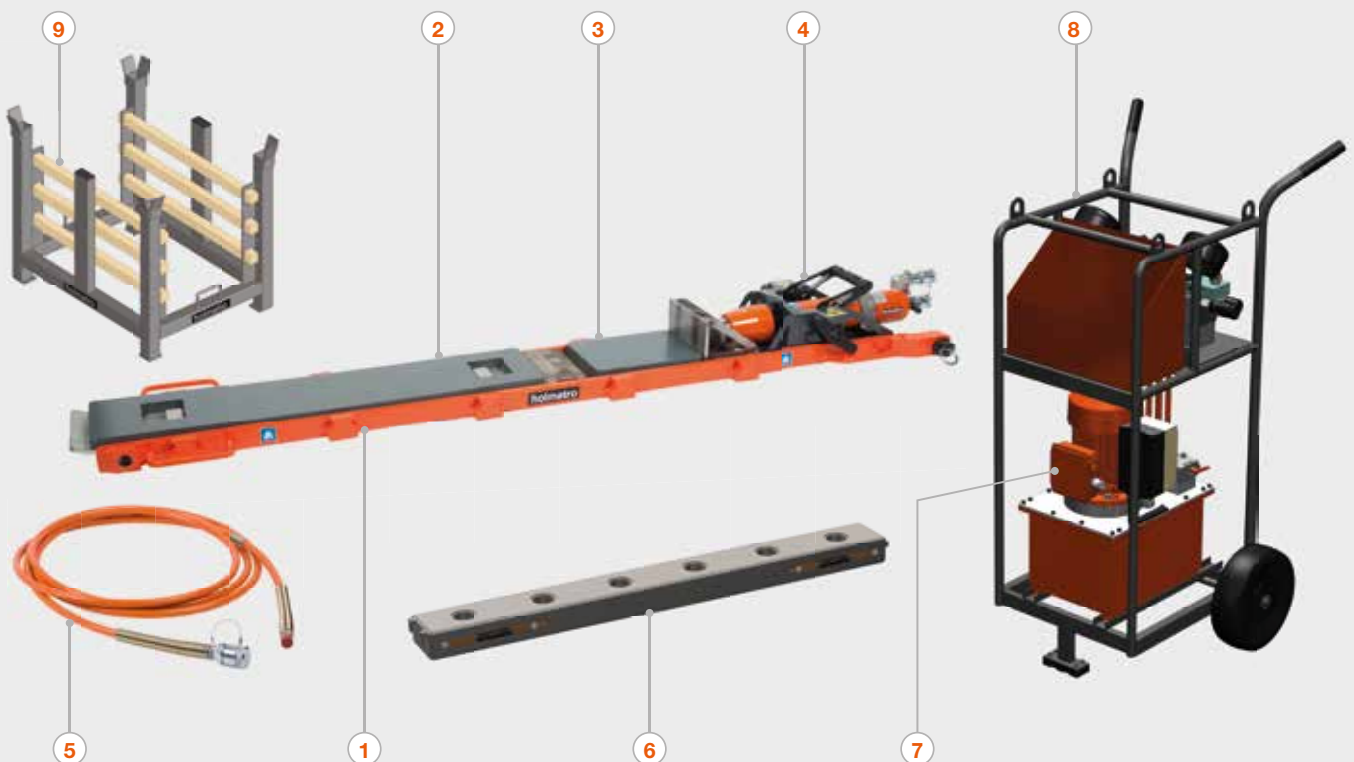

Holmatro has developed extra high beams (6) for situations where the load does not connect with the front of the push-pull unit. These are form fit the standard beams, so that the total weight is optimally distributed across the entire system.

The Skidding System is driven by a powerful Twin pump (7). The system is standard supplied with a pump trolley (8) for easy movement of the pump, and a storage frame (9) to store the tracks.

\*The exact unsupported span distance depends on the weight and positioning of the load. For more information, please contact us.



## Skidding System

<b>Lightweight Skidding System (200 tons)</b>			
<b>image</b>	<b>description</b>	<b>model</b>	<b>qty</b>
	Push-pull unit	SPPU-LW	2
	Push-pull bracket	SPPB-LW	2
	Beam 1.8	SB-LW 1.8	2
	Beam 1	SB-LW 1	2
	High beam 1.8	SHB-LW 1.8	-
	High beam 1.2	SHB-LW 1.2	-
	Track	ST-LW	8
	Extension hoses	VL 10 SOU	4
	Skidding twin pump	09 T 12 E	1
	Storage frame	STSF-LW	1

### Features and benefits

- 200-ton capacity (2 X 100 t)
- Low construction height; total height is 56 mm (2.20 inches)
  - Efficient when there is limited insertion space
- Lightweight components with optimally placed grips
  - Easy to carry, handle, position and assemble by one or two persons (no forklift needed)
  - Reduces the physical burden
  - Maximum performance at a minimum weight
- Modular system
  - Easy to adapt to different load sizes and projects
  - Plug and play; easy to assemble without the use of extra equipment
- Push-pull cylinder with equal capacity for both pushing and pulling
  - Ability to push or pull the load into position, instead of only pushing
  - Accurate control in both directions
- Change of direction by the use of a handle; push or pull direction can be switched in a split of a second
- Internal return line in push-pull cylinder
  - Reduces the chance of damage to the line
  - Equal hose length for ingoing and outgoing oil
- Safe; integrated safety features in the push-pull cylinder for protection against overpressure
- High beams form fit the standard beams; in case of loads whereby the contact surface not entirely fits on the front side of the push-pull unit
  - Total load is optimally spread across the entire system
- Sliding pads with extremely low friction coefficient; low sliding resistance between tracks and beams

### Standard supplied with

- Pump trolley; easy to move the pump
- Storage frame; storing the tracks

# Standard Skidding System (400 tons)

extremely strong and robust

Holmatro's standard Skidding System consists of robust, shock-resistant parts. The maximum capacity of the system is 400 tons, assuming two skidding units are used as described in the starter kit at the next page. The total construction height is 244 mm (9.61 inches) and can carry loads over a relatively large unsupported span when the surface is uneven.\*

The tracks (1), with a standard length of 2 meters, are easy to connect to each other using steel pins. Extremely rigid steel beams (2) with a stainless steel sliding surface are placed in the tracks, which reduces the resistance on the tracks and the chance of bending at small loads to virtually zero. The push-pull units (3) are fitted with easy to dismantle wings that allow the push or pull direction of the system to be changed quickly. The cylinders in the push-pull units are connected with hydraulic hoses (4) to a powerful Twin pump (5).

The Skidding System is standard supplied with a pump trolley (6) for easy movement of the pump, and a storage frame (7) to store the tracks.





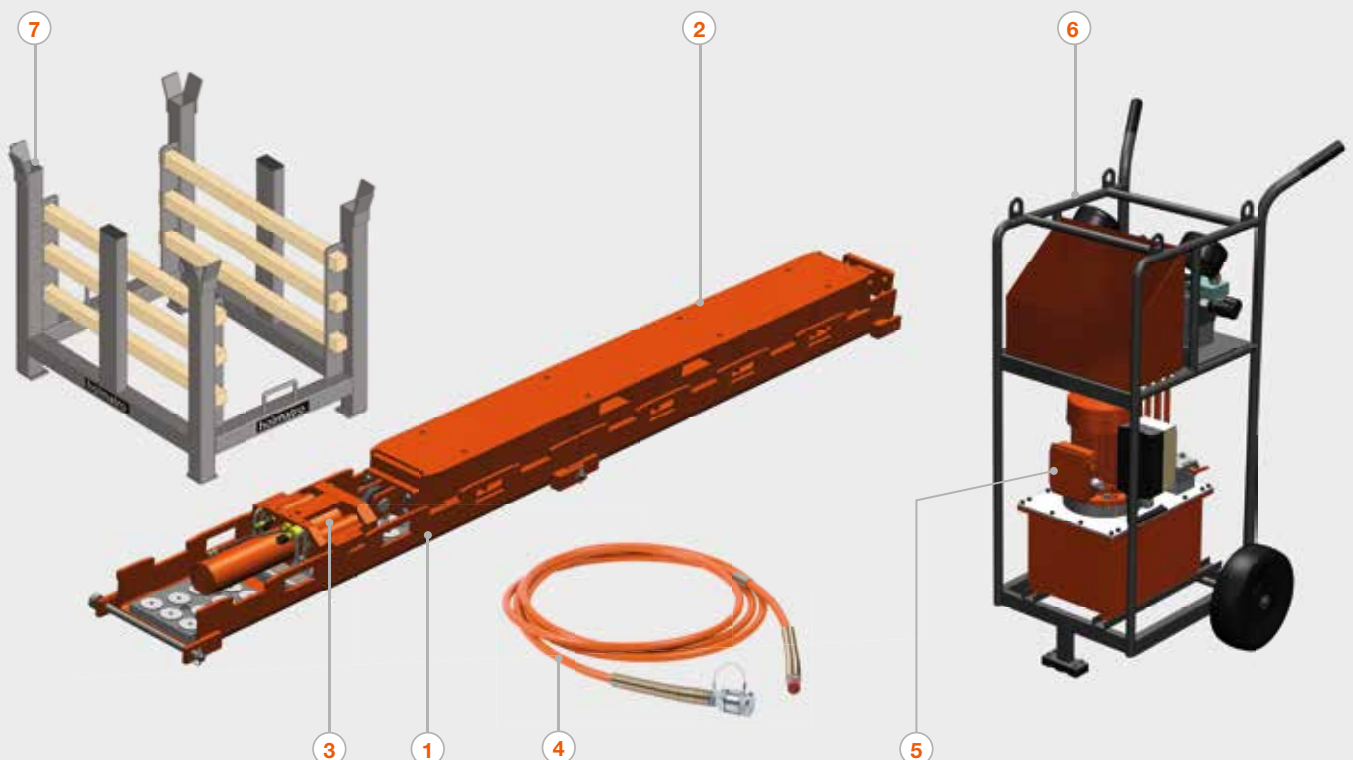

\* The exact unsupported span distance depends on the weight and positioning of the load. For more information, please contact us.

**CIS** LTD.  
**HYDRAULIC SOLUTIONS**





## Skidding System

<b>Standard Skidding System (400 tons)</b>			
<b>image</b>	<b>description</b>	<b>model</b>	<b>qty</b>
	Push-pull unit	SPPU-S	2
	Beam	SB-S	2
	Track	ST-S	8
	Extension hoses	VL 10 SOU	4
	Skidding twin pump	09 T 12 E	1
	Storage frame	STSF-S	1

### Features and benefits







- 400-ton capacity (2 X 200 t)
- Extremely rigid beams; does not bend with small loads
- Modular system; easy to adapt to different load sizes and projects
- Push-pull cylinder with equal capacity for both pushing and pulling
  - Ability to push or pull the load into position, instead of only pushing
  - Accurate control in both directions
- Demountable wings; push or pull direction can be switched quickly

- Safe; integrated safety features in the push-pull cylinder for protection against overpressure
- Sliding pads with extremely low friction coefficient; low sliding resistance between tracks and beams

### Standard supplied with

- Pump trolley; easy to move the pump
- Storage frame; storing the tracks

## Also available

<b>Optional products</b>	
<b>image</b>	<b>description</b>
	Pumps with different engines (petrol/diesel) and/or flow speeds
	Hoses with different colors and/or lengths
	Hydraulic cylinders
	Mechanical Jacks
	Lifting bags
	Chocks & blocks
	Hand and foot pumps



# About Holmatro Industrial Equipment

## **Feel the power**

Holmatro industrial tools offer flexible, implementation-oriented and controllable power, from 5 - 1500 tons. We develop, manufacture and test superior quality hydraulic tools for a wide variety of industrial applications. Products that are combined with digital operating technologies also form the basis for a wide spectrum of advanced industrial solutions.

## **Innovation**

Our experience with high-pressure hydraulics enables us to push the boundaries of what is technically possible. This results in lighter, more compact, durable and user friendly tools.

## **Expertise & quality**

Our focus is on high-pressure hydraulics and our sole purpose is to manufacture superior quality tools. Quality is therefore key across the entire logistics chain.

## **Clean & high-tech production**

Holmatro tools are manufactured and assembled in high-tech production environments, often with the assistance of robots. We follow extremely stringent rules and procedures with a view to a clean environment.

## **200% tested**

After production or repair, an assembly technician tests all our tools. They subsequently undergo an additional test in the Quality Control department. This gives you 200% certainty.

## **Support & safety**

Clients choose Holmatro for life. We therefore provide support during the entire life span of our products. Our comprehensive certification program ensures that you can use our tools safely.

## **Maintenance**

Thanks to comprehensive knowledge of the entire life span of our products, we can provide you with optimal maintenance advice. Regular maintenance ensures reliable operation and a longer life span for your tools. Spare parts are always available.

## **Hallmarks**

Innovation, quality and service are at the heart of our company philosophy. All of our products meet the most stringent inspection regulations.



MultiSafe®

holmatro

Feel the  
power

holmatro  
mastering power

www.holmatro.com

**(Inter)national sales network**

Our experience of many years and in-house engineering enable us to provide you with expert advice on both our products and applications. Our sales organization and dealers - fully trained in our own training center - guarantee the same Holmatro standard of quality.

Holmatro is a multinational organization consisting of a group of companies operating in 5 different countries.



**CIS** LTD.  
**HYDRAULIC SOLUTIONS**

CIS (Holmatro) Ltd, 25 Hatton Close, Moulton Park Ind. Est., Northampton, NN3 6SU. Tel:- +44(0) 1604 642020 | Fax:- +44(0) 1604 642323

Web:- [www.holmatro.co.uk](http://www.holmatro.co.uk) Mail:- [sales@holmatro.co.uk](mailto:sales@holmatro.co.uk)



© Holmatro 00 1016 980.000.669

**Disclaimer**

While the greatest care has been devoted to the content, it is possible that the information in this printed matter is incorrect or incomplete. N.V. Holmatro and its affiliated companies (hereafter: Holmatro) cannot be held liable in any way for the consequences of activities undertaken based on this printed matter. If you have any doubts about the correctness or completeness of the information, you shall contact Holmatro (phone number: +31 (0)162-751500).

Nothing from this printed matter can be copied and/or made public in any way without the explicit authorisation of Holmatro.

